

TRADE DATA – PV RANGE

ROOM SEALED/FAN ASSISTED FLUE GAS CABINET HEATERS



PVN



For models -
PVN Vertical Nozzled
PVD Vertical Ducted



RANGE & CONFIGURATION

Room Sealed or Fan Assisted Flue Gas Fired Vertical Cabinet Heater

Nozzled Discharge 29.4 kW to 144.0 kW

Ducted Discharge 29.4 kW to 144.0 kW

SPECIFICATION

CABINET: Machine punched and folded from electro-zinc coated steel to form a robust monocoque case construction. Access to the burner and controls compartment is via a front full width hinged door. The cabinet is epoxy powder coated with a durable Kestrel Grey paint finish.

HEAT EXCHANGER: Formed from aluminised steel tube into a compact yet highly efficient four pass 'S' shaped assembly the PV heat exchanger has been designed so that manufacture can be accomplished without the use of any stress inducing welding processes. Stainless steel heat exchanger tubes available as an option.

BURNER: PV family heaters are fitted with a quiet multi-flame low Nox burner which in turn is complete with automatic electronic spark ignition and ionisation flame proving. The burner, in conjunction with the heat exchanger is capable of delivering efficiencies in excess of 91% nett.

ECA APPROVED: The PV range easily meets the Government's energy efficiency criteria for inclusion into the Enhanced Capital Allowance scheme. Please contact our sales office for further details.

FUEL: Heaters can be specified to operate on either natural gas (G20) or Lpg (Propane G31).

SEALED COMBUSTION CIRCUIT: PV heaters are all factory fitted with a power flue venter that enables the heater to be operated in either room sealed or fan assisted flue mode. The flue fan is safety interlocked with the burner control system via a pressure differential sensor.

AIR DISTRIBUTION: Free blowing heaters are fitted with aerodynamic discharge nozzles each of which can be rotated through 360°. Each nozzle is fitted with adjustable horizontal louvre blades to provide lateral distribution. Models 250 and above include raised nozzles (one per three nozzled heater and two per four nozzled heaters) however for height sensitive applications lower standard nozzles can be specified. Heaters for ducted applications are supplied with a duct outlet spigot.

Generally return air to the heaters is via louvred inlet panels permitting air entry directly into the fan compartment. However heaters can, as an option, be fitted with alternative return air arrangements including fresh air spigots and filters.

CONTROLS: PV cabinet heaters are supplied ready for fully automatic operation and are complete with both safety and comfort controls. Each heater is fitted with a safety overheat thermostat as well as a time and temperature control system. Two alternative control options are available.

As standard, heaters are fitted with a digital time switch, mechanical day temperature and frost protection thermostats. Alternatively heaters may be specified with a fully optimised control which includes a secure entry code facility, temperature dependent start time, digital time switch with override facility, electronic day thermostat and frost protection thermostat.

Unless otherwise specified the controls are factory fitted. As an option controls can be supplied within a console for remote mounting. Inter-connecting wiring between heater and remote consoles is by others.

All heaters have the facility of 'fan only' operation for summer air movement.

TESTING, APPROVALS & CERTIFICATION:

Benson Heating is accredited with ISO 9001 quality assurance certification – certificate number FM14923. All gas fired heaters have been type tested and approved to CE standards by an independent notified body. Each heater is function tested and fired prior to despatch.

GUARANTEE: PV cabinet heaters are provided with a comprehensive guarantee package which covers both parts and labour for the first twelve months with a further twelve months parts only. The tubular heat exchanger has the benefit of a ten-year time related warranty. Guarantees subject to terms and conditions.

QUICK REFERENCE DATA

Power Vented Vertical Cabinet Heater

Natural Gas and Lpg Propane - PVN PVD

Model			100	170	250	330	410	490	
Output	All	kW	29.4	49.0	72.0	96.0	120.0	144.0	
		Btu/h(K)	100	167	246	328	409	491	
Airflow	All	m ³ /s	0.80	1.05	1.50	2.00	2.50	3.00	
		ft ³ /m	1695	2225	3179	4238	5298	6357	
Electrics	All	V/ph/hz	230/1/50			415/3/50			
Overall Dimensions	PVN	Height	mm	1908	1974	2599	2599	2817	2817
	PVD	Height	mm	1725	1725	2050	2050	2200	2200
	All	Width	mm	700	700	840	840	840	840
	All	Depth	mm	1050	1050	1395	1395	1750	1750
Flue Combustion Air	All	mm ø	100	100	130	130	130	130	
		mm ø	100	100	130	130	130	130	
Nett Weight	PVN	kg	192	202	330	350	440	460	

Note -

Overall height includes extended heads (where applicable)

AIR HANDLING DATA

Power Vented Vertical Cabinet Heater

Natural Gas and Lpg Propane - PVN PVD

Model			100	170	250	330	410	490	
Output	All	kW	29.4	49.0	72.0	96.0	120.0	144.0	
		Btu/h(K)	100	167	246	328	409	491	
Airflow	All	m ³ /s	0.80	1.05	1.50	2.00	2.50	3.00	
		ft ³ /m	1695	2225	3179	4238	5298	6357	
Nozzle Detail	PVN	No.	2	2	3	3	3	4	
		Width	mm	280	280	280	280	308	308
		Height	mm	190	280	280	280	308	308
		Throw	m	18	19	19	26	29	26
			ft	59	62	62	85	95	85
Fan Static Pressure	PVD	Pa	80	110	110	110	150	150	
		in wg	0.32	0.44	0.44	0.44	0.60	0.60	
Outlet Duct Spigot (OD)	PVD	Width	mm	570	570	769	769	769	769
		Depth	mm	570	570	984	984	1339	1339

Note -

Air handling data is assessed at room ambient conditions
Throw figures provide the distance to the point where the average air velocity is 0.25m/s

INSTALLATION REQUIREMENTS

INSTALLATION STANDARDS: Benson PV gas cabinet heaters must be installed by a competent person and in accordance with relevant standards, Codes of Practice, the requirements of the current Building Regulations, Health and Safety Regulations, IEE Regulations and any requirements of the Local Authority, Fire Officer or insurers. Relevant standards may include BS 6230, BS 6891 and BS 5588 parts 2 and 3.

SITING: The position chosen for the heater will need to take account of the following points -

All heaters should be mounted on a flat non-combustible base capable of supporting the weight.

Care should also be taken to ensure that the recommended clearances for maintenance, air discharge, return and re-circulation are observed.

Further information is provided in the Installation Data table on the page opposite.

Consideration should be given to the route and length of the flue, the provision and connection of gas and electrical supplies, potential public access issues and protection from overhead cranes, fork lift trucks etc.

For effective warm air distribution free blowing heaters should be both selected and positioned to take account of the throw characteristics and sited such that the discharge avoids any immediate obstructions, partitions or other significant obstacles. In areas where it is proposed to install more than one heater then a general scheme of uniform air circulation should be employed to provide optimum distribution.

Generally, heaters will be operated with in-built controls and temperature sensors which carefully monitors the return air temperature. In applications where heaters are installed with fresh air intakes then consideration should be given to ensure that the control and/or temperature sensors are re-located in a position which adequately reflects the working zone serviced by the heater. Sensors should not be located in areas subject to cold draughts. In case of doubt relating to any aspect of heater or control siting please consult with Benson Sales.

GAS PIPEWORK: The gas supply pipework must be sized and installed with due regard for all current standards and legislation, flow rates and the maximum/minimum inlet pressure requirements of the heater. Isolating gas cocks and service unions must be provided adjacent to each heater.

SPECIAL RISK AREAS: Where it is proposed to install a heater within a special risk area (including but not limited to areas containing flammable vapours, where petrol engined vehicles are stored, parked or serviced, where paint spraying occurs or where wood working or other flammable dust creating process are employed) then restrictions, additional regulations and requirements concerning the heater installation may apply. Additionally areas containing chlorinated or halogenated hydrocarbons, degreasing solvents, styrene's, other laminating materials or airborne silicones can cause corrosion to heat exchange surfaces and It is strongly recommended that you consult Benson Sales before installation commences. Failure to do so may invalidate or reduce guarantee cover.

CAUTION: When specified in certain configurations it may be possible to install heaters in areas containing flammable vapours, high levels of airborne dust, combustible dust, chlorinated or halogenated hydrocarbons, degreasing solvents, styrene's, other laminating materials or airborne silicones however before doing so consult Benson Sales.

PLANT ROOM SITING: Provided certain criteria are met it is possible to install PVD (ducted outlet) heaters within plant rooms. Heaters installed in plant rooms should only be configured for use in room sealed mode and provision should be made for the positive connection of flues, combustion air ductwork, warm air discharge and return air ductwork. Where such a siting is a requirement it is recommended that you consult Benson Sales prior to installation.

AIR SUPPLY: The provision of an air supply for combustion, for combustion product dilution if relevant, and for ventilation varies according to heater location. Where the heater is sited directly within the space to be heated and used in fan assisted flue mode (ie without the positive connection of the combustion air ductwork to atmosphere) then consideration of ventilation for combustion air and general ventilation is mandatory with the requirements dependent upon the ratio between heat input and building volume or the air change rate of the building. If the heater is to be sited directly into the space to be heated and used room sealed mode the provision of a combustion air supply for the building is not necessary however the need for general ventilation may remain. Where the heater is to be sited within a plant room then it is recommended that it be operated in room sealed mode. General ventilation of the plant room will be a requirement. In all cases it is recommended that BS 6230 be used as a consultative document.

FLUES: PV heaters are approved for use in both room sealed and fan assisted flue format. The in-built flue fan permits the heater to be sited several metres away from the point of flue/combustion air ductwork exit.

Flue and combustion air spigots are situated on the top face of the heater from which flues/combustion air ductwork may be run either horizontally or vertically. The diameters of flue and combustion air ductwork must not be less than stated in the Reference Data sections of this brochure. Benson offer a full range of compatible flue and it is strongly recommended that this flue be used.

The maximum permitted lengths given in the Installation Data table on the following page are for guidance purposes and installers should be mindful that the inclusion of 45° and 90° flue bends will reduce the total available length on the basis that every 45° bend is equivalent to 0.5 metres of straight flue and every 90° bend if equivalent to 1.0 metres of straight flue.

The flue route and exit point needs to be selected carefully and it is recommended that the installer consult the PV Installation, Operating and Maintenance manual before commencing installation. Additionally BS 5854 and BS 5440 should be used as consultative documents.

FURTHER INFORMATION: The foregoing is given for guidance purposes. More detailed information can be found within the relevant Installation, Operating and Maintenance manual or alternatively contact Benson Sales.

INSTALLATION DATA

Power Vented Vertical Cabinet Heater

Natural Gas/Lpg Propane - PVN PVD

Model			100	170	250	330	410	490			
Output	All	kW	29.4	49.0	72.0	96.0	120.0	144.0			
		Btu/h(K)	100	167	246	328	409	491			
Fuel Consumption	Natural Gas	m ³ /h	3.38	5.63	8.33	11.12	13.87	16.63			
		ft ³ /h	119	199	294	393	490	587			
	Lpg Propane	m ³ /h	1.30	2.16	3.21	4.28	5.34	6.41			
		kg/h	2.41	4.00	5.94	7.92	9.88	11.86			
Minimum Gas Inlet Pressure	Natural Gas	mbar	17.5	17.5	17.5	17.5	17.5	17.5			
		in wg	7.0	7.0	7.0	7.0	7.0	7.0			
	Lpg Propane	mbar	37.0	37.0	37.0	37.0	37.0	37.0			
in wg		14.8	14.8	14.8	14.8	14.8	14.8				
Connection	All	BSP/Rc	½	½	¾	¾	¾	¾			
Electrics	All	Supply	V/ph/hz			230/1/50			415/3/50		
		FLC	Amp	6.2	6.2	8.4	3.6	3.6	4.9		
Flue	All	mm ø	100	100	130	130	130	130			
		mm ø	100	100	130	130	130	130			
Maximum Run	All	Horiz	m	6.0	6.0	8.0	8.0	8.0			
		Vert	m	10.0	10.0	10.0	10.0	10.0			
Installation Clearances	All	Front	mm	700	700	840	840	840			
		Side	mm	150	150	150	150	150			
		Rear	mm	400	400	400	400	400			
Noise Level	PVN	dBA	58	60	66	68	69	72			
Nett Weight	PVN	kg	192	202	330	350	440	460			

Note -

Flue and combustion air maximum runs for guidance purposes only. Please refer to installation instructions for detailed information

Noise levels measured 3m from appliance

Fuel consumption and output figures based upon gross calorific values as -

Natural gas (G20) @ 37.78 MJ/m³

Lpg Propane (G31) @ 95.65 MJ/m³

DIMENSIONS

Power Vented Vertical Cabinet Heater

Natural Gas and Lpg Propane - PVN PVD

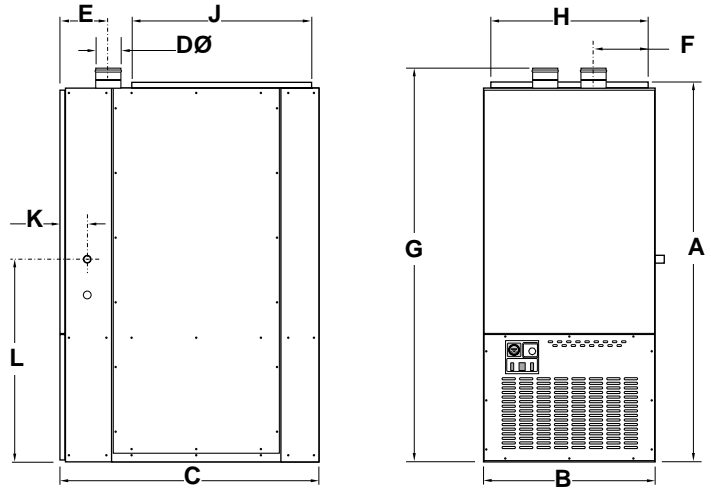
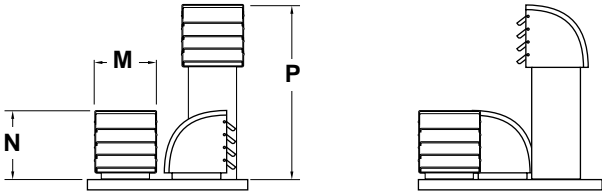

Model			100	170	250	330	410	490
A	All	mm	1650	1650	1990	1990	2140	2140
B	All	mm	700	700	840	840	840	840
C	All	mm	1050	1050	1395	1395	1750	1750
D	All	mm ø	100	100	130	130	130	130
E	All	mm	189	189	255	255	255	260
F	All	mm	263	263	311	311	283	287
G	All	mm	1725	1725	2050	2050	2200	2200
H	All	mm	570	570	769	769	769	769
J	All	mm	570	570	984	984	1339	1339
K	All	mm	103	103	169	169	95	95
L	All	mm	967	840	1091	977	1113	1033
M	All	mm	280	280	280	280	314	314
N	All	mm	258	324	324	324	352	352
P	All	mm	n/a	n/a	609	609	677	677

Return Air Details

Side Return Air Inlet

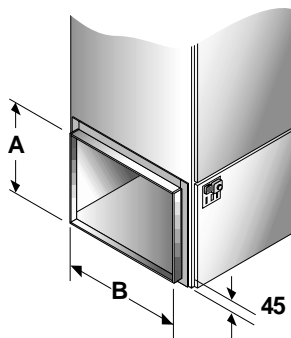

Rear Return Air Inlet

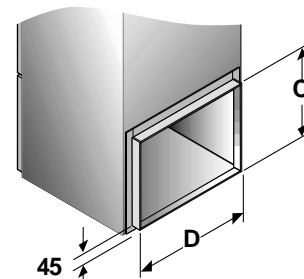

Model			100	170	250	330	410	490	
Side Inlet Spigot	All	A	mm	348	348	427	427	640	640
		B	mm	522	522	702	702	1155	1155
Rear Inlet Spigot	All	C	mm	468	468	640	640	640	640
		D	mm	650	650	677	677	677	677

Note -
Side inlet spigots require to be specified either left hand or right hand

FLUEING SYSTEMS

Horizontal flue only

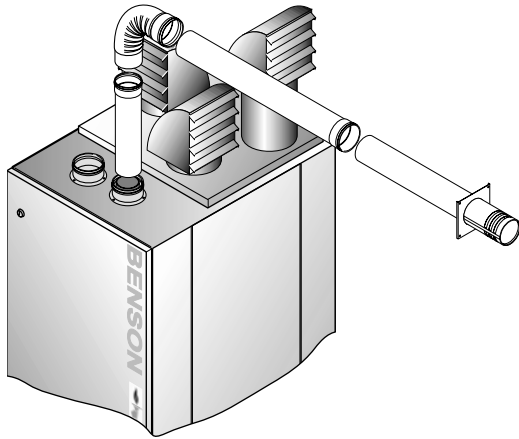

Vertical room sealed via co-axial flue

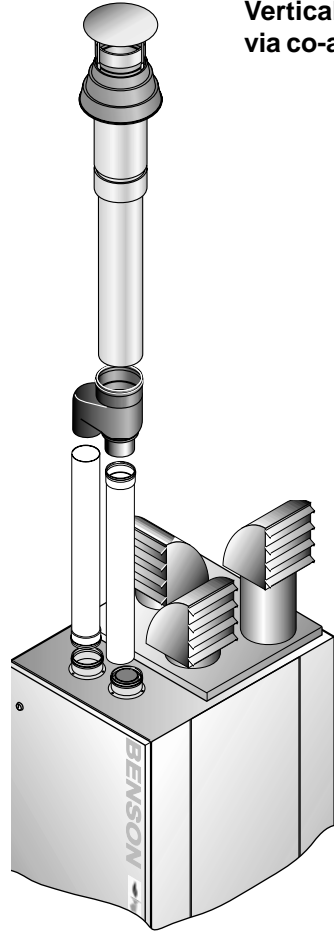

Horizontal room sealed via separate flues

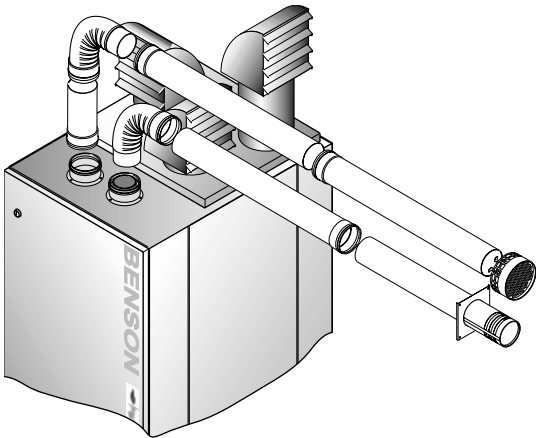

Vertical flue only

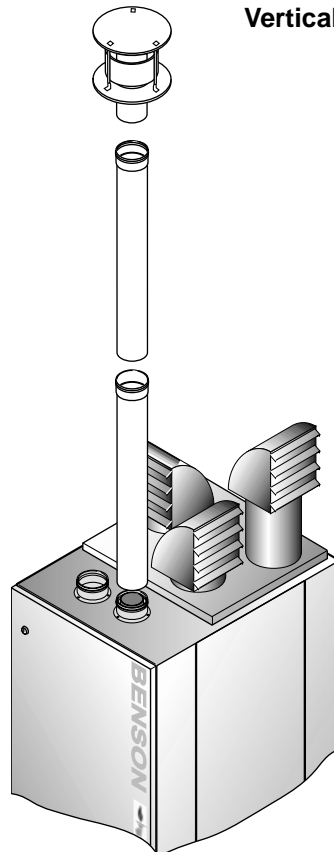

Horizontal room sealed via co-axial flue

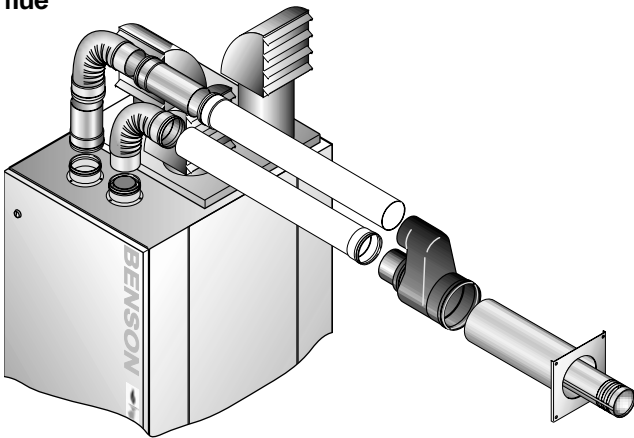

Note -

Flue components shown shaded from the horizontal and vertical co-axial flue kits
The drawings above are indicative of typical arrangements. For actual installation details please refer to the Installation and Operating manual

INFORMATION

BENSON HEATING PRODUCTS

Oil and gas forced draught cabinet heaters
Oil and gas fired external cabinet heaters
Room sealed/fan assisted flue gas fired cabinet heaters
Room sealed/fan assisted flue gas fired unit heaters
Oil fired unit heaters
Combination heating and cooling units
Door curtains
Exchange modules
Marquee heaters
Cast iron boilers
Flue and accessories

SALES HOT LINE: 01547 529245
SALES FAX LINE: 01547 529195
TECHNICAL HELP LINE: 01547 528534
Email: information@bensonheating.co.uk
Web: www.bensonheating.com

BENSON HEATING
LUDLOW ROAD
KNIGHTON, POWYS
LD7 1LP
Tel: 01547 528534
Fax: 01547 520399

BENSON HEATING IS A DIVISION OF BENSON CLIMATE SYSTEMS LIMITED



*Guarantees and warranties subject to terms and conditions. It is the policy of Benson Heating to pursue a programme of continuous development. We therefore reserve the right to change model types, specifications and prices without prior notice. Details are believed to be correct but do not form the basis of any contract or guarantee. All orders accepted subject to our standard conditions of sale copy available upon request.